

# Installation

## 1. Whole view

- Packing granule



- Packing powder



## 2. Installation of Z feeder

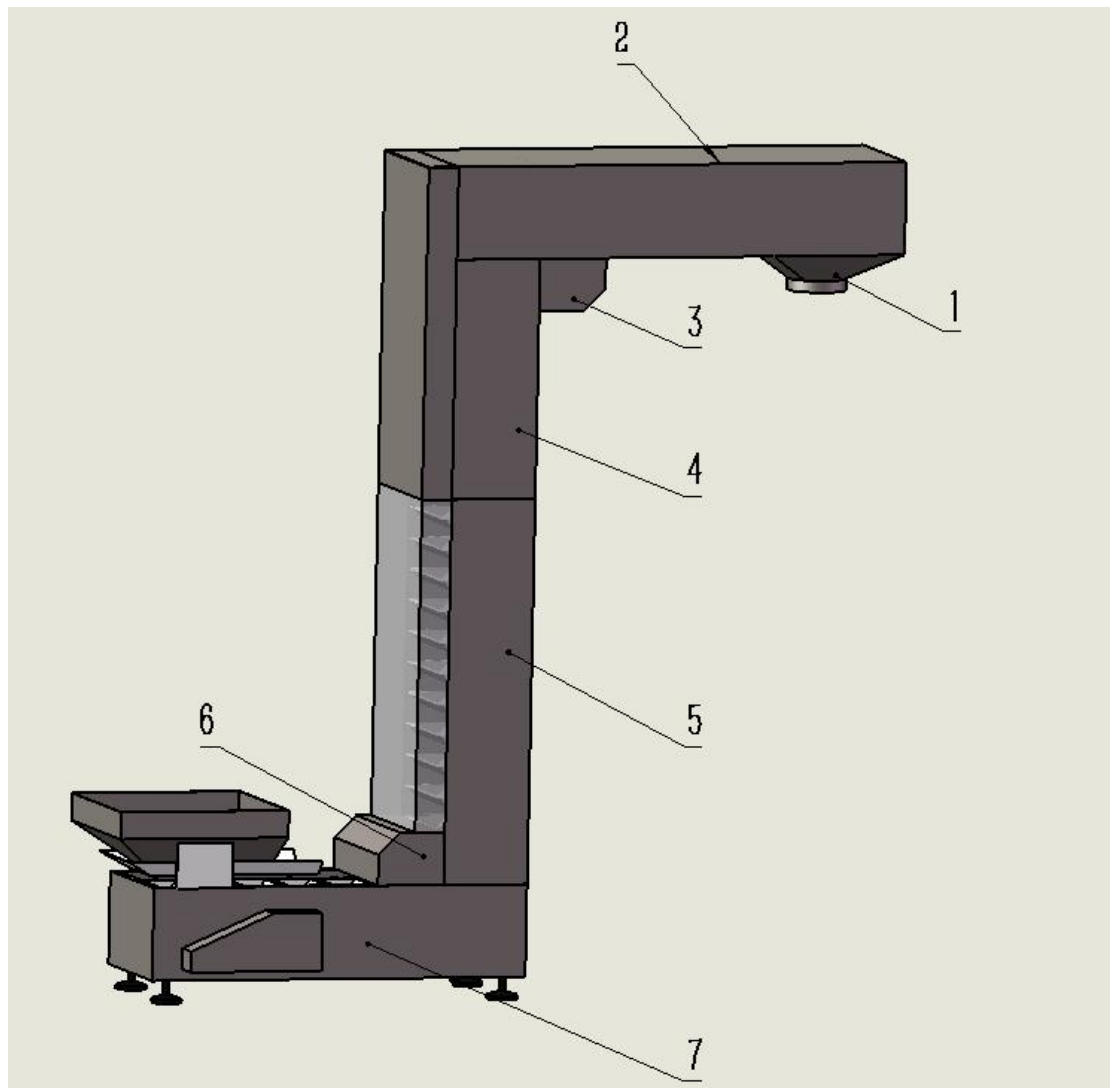

- 1) Assemble pieces 2, 4, 5, 7 (each piece has its mark number)
- 2) Connect two chains
- 3) Turn on the feeder and put on buckets
- 4) Close the back of 4, 5 (transparent pieces)
- 5) Assemble 1, 3, 6

### 3. Installation of screw feeder

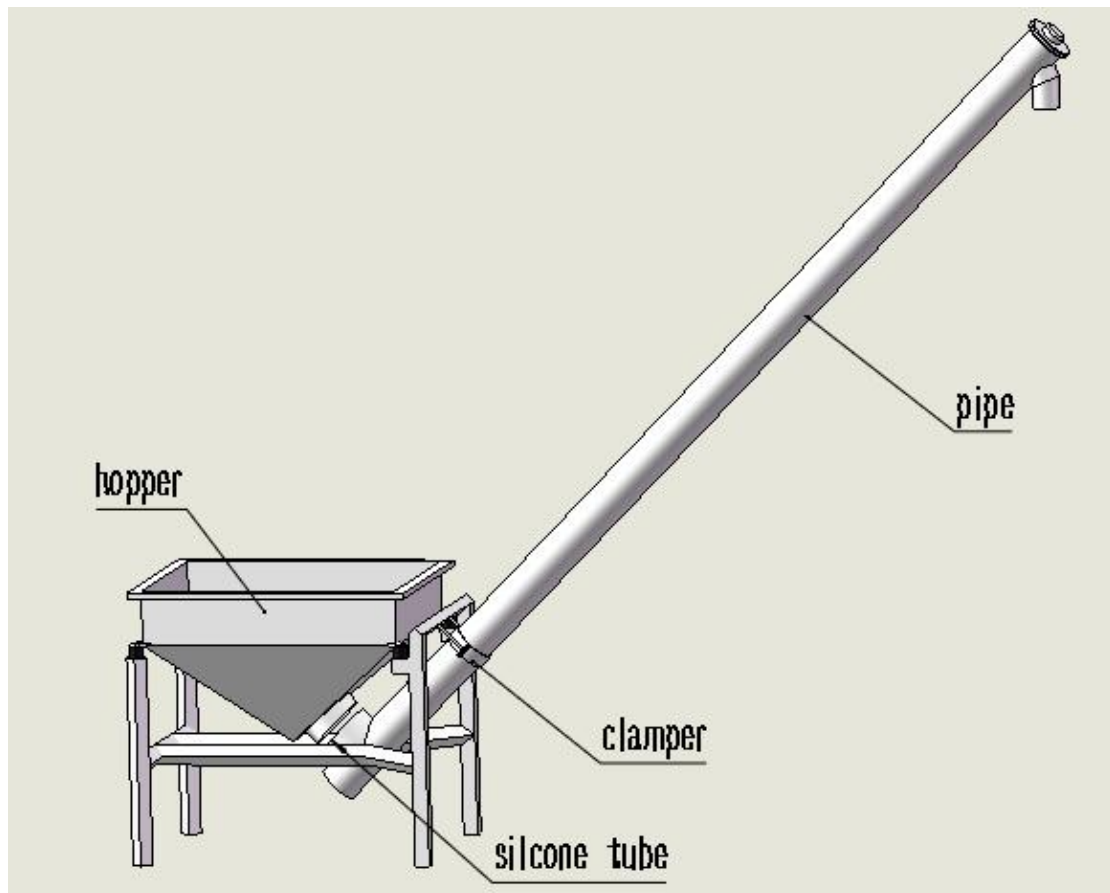

- 1) Pipe and hopper are in two crates
- 2) Connect pipe and hopper by clamber

### 4. Installation of platform

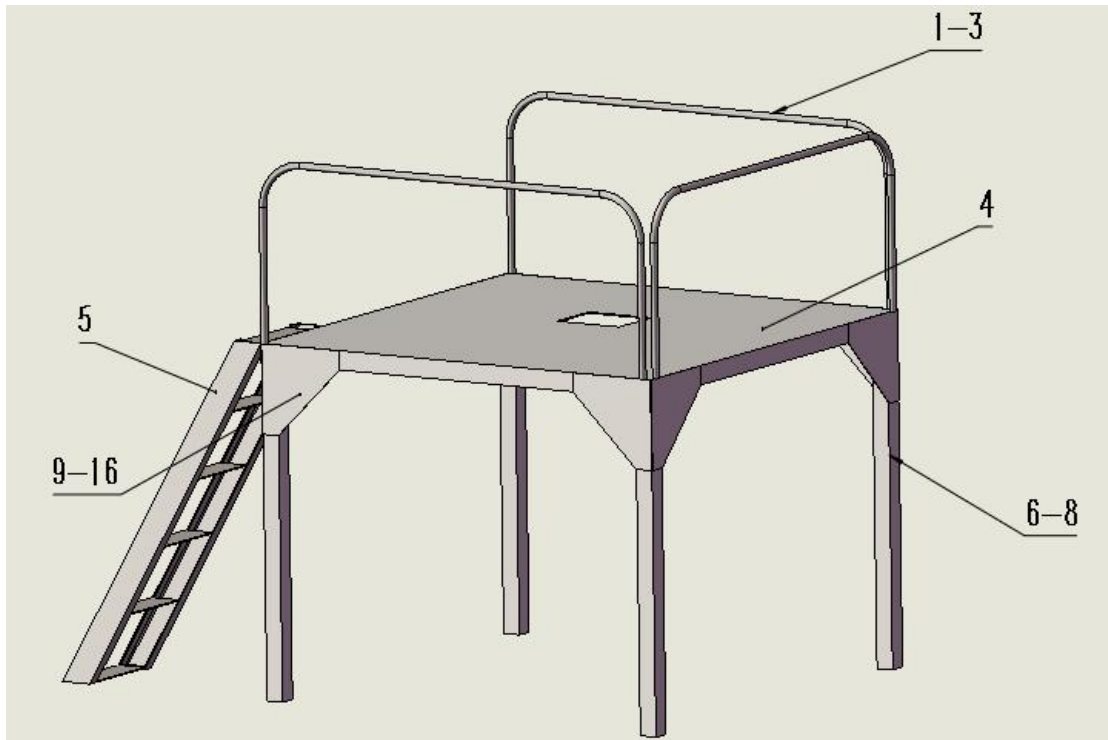

## 5. Installation of multi-weigher

Please refer to its manual

## 6. Connection of main machine

BACK VIEW

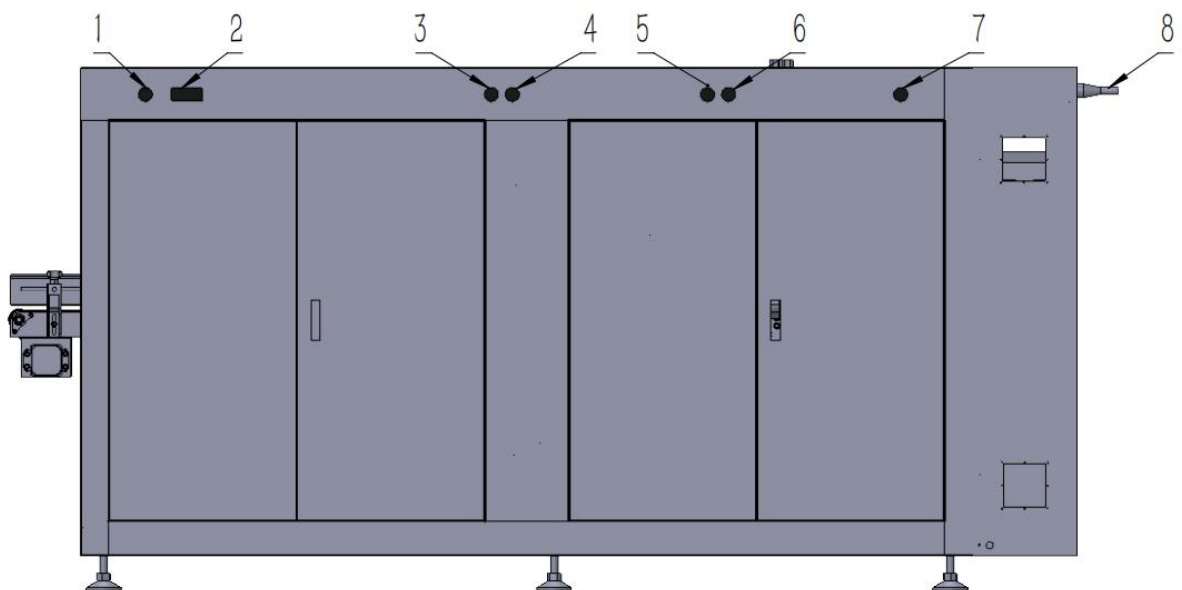

The main machine controls on/off of:

- auger filler
- screw feeder
- multi-head weigher
- Z feeder

On the back of main machine, there are socket for accessories' plug:

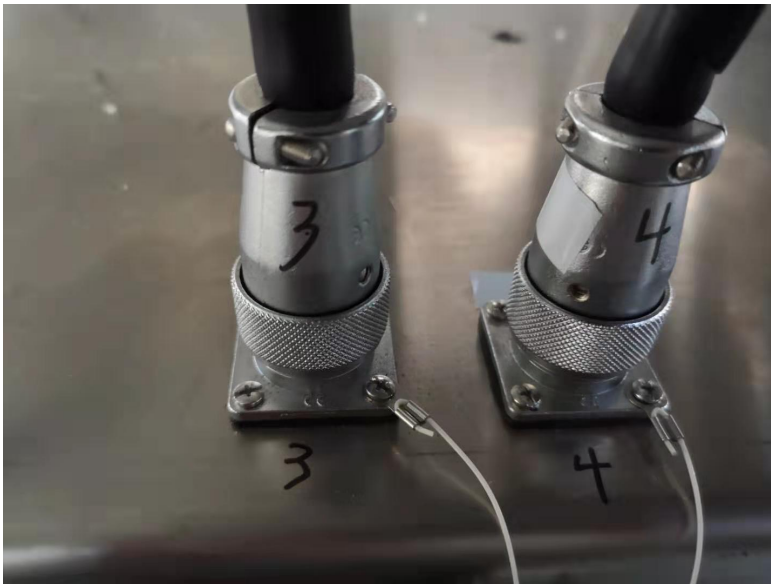

The sockets are:

- 1) Screw feeder
- 2) Auger filler
- 3) Signal plug 1 of muti-head weigher
- 4) Signal plug 2 of muti-head weigher
- 5) Plug 1 of Z feeder
- 6) Plug 2 of Z feeder
- 7) Signal wire of dessicant inserter
- 8) Connect to air hose of dust collector

It will need additional power supply for:

- dust collector: 3P 1.75KW
- dessicant inserter: 1P 0.5KW
- multi-head weigher: 1P 1.5KW
- main machine: 3P 4.5KW