

REVISIONS			
REV.	DESCRIPTION	DATE	APPROVED
-	-	-	-

PRELIMINARY DESIGN

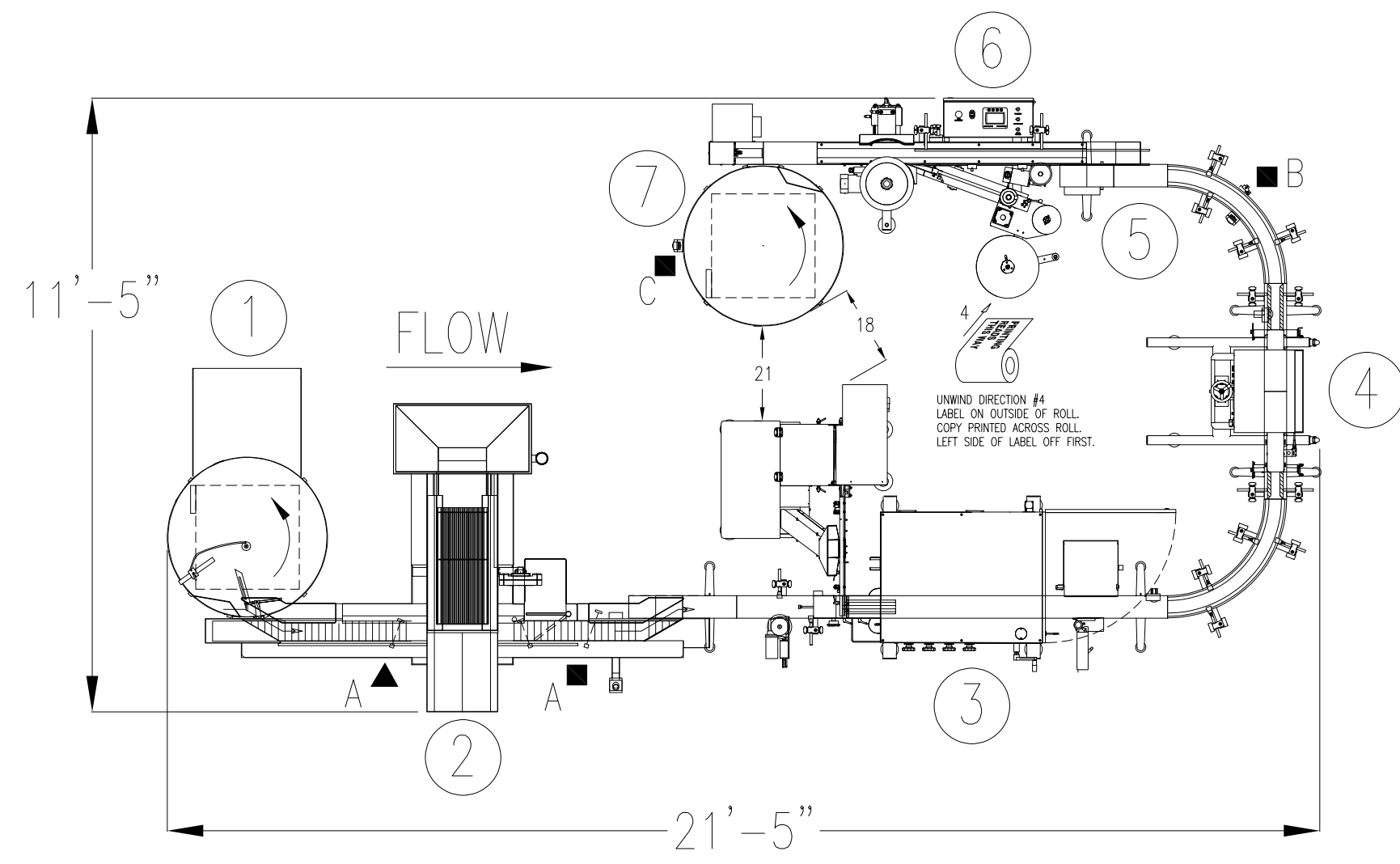

NO	DESCRIPTION	MACHINE		FUSE				SWITCHES		VACUUM AT 12"
		VOLTAGE	PHASE	AMPS	Hz	PSI	SCFM	PRIME	BACK-UP	OF WATER (SCFM)
①	NJM ϕ 36" INLET TURNTABLE	120	1	1.5	60	N/A	N/A			N/A
②	CREMER CF1220 TABLET COUNTER	208	1	6.5	60	90	6	▲ A	■ A	TBD
③	NJM UNICAP 150 CAPPER	208	1	12	60	90	6		■ B	N/A
④	ENERCON MODEL 700 INDUCTION SEALER	208	1	10	60	N/A	N/A		■ B	N/A
⑤	NJM 22'-0" CURVED CONVEYOR	120	1	5-15	60	N/A	N/A			N/A
⑥	NJM MINICOLT LABELER	120	1	12	60	80	2		■ C	N/A
⑦	NJM ϕ 36" OUTLET TURNTABLE	120	1	1.5	60	N/A	N/A			N/A

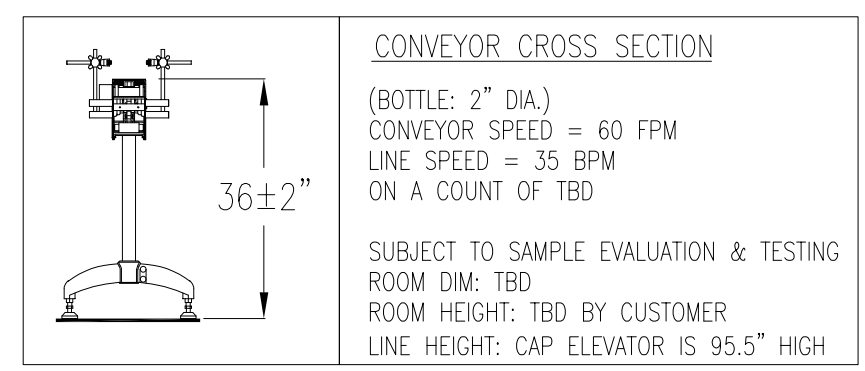

NEXPHARMA 1R0

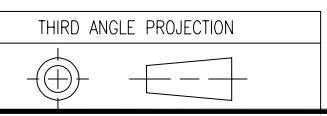

UNLESS OTHERWISE SPECIFIED DIMENSIONS ARE IN INCHES. TOLERANCES DECIMALS : X = ± .5" ANGLES : ± 0°.30' FRACTIONS : ± 1/2"	SIGNATURES		DATE	 LEBANON, NH 03766-1403 USA 5600 KIERAN, MONTREAL QC, H4S 2B5, CANADA
	DRAWN JOS		2022/05/06	
	CHECKED			
	ENGRD			
ISSUED				LINE LAYOUT NEXPHARMA
LASER SCALE COPY		COMMAND # :		SIZE D
		OPERATION # :		ENGINEERING DEPARTMENT
				DWG NO. NEXPHARMA 1R0
				SCALE: NTS WEIGHT : SHEET 1 OF 1